



## WARNING

PLEASE READ THE ENTIRE CONTENTS OF THIS MANUAL PRIOR TO INSTALLATION AND OPERATION. BY PROCEEDING YOU AGREE THAT YOU FULLY UNDERSTAND AND COMPREHEND THE FULL CONTENTS OF THIS MANUAL. FORWARD THIS MANUAL TO ALL OPERATORS. FAILURE TO OPERATE THIS EQUIPMENT AS DIRECTED CAN MAY CAUSE INJURY OR DEATH.

# INSTALLATION AND OPERATION MANUAL

## ATC-1500

### Fully Automatic Truck Tire Changer

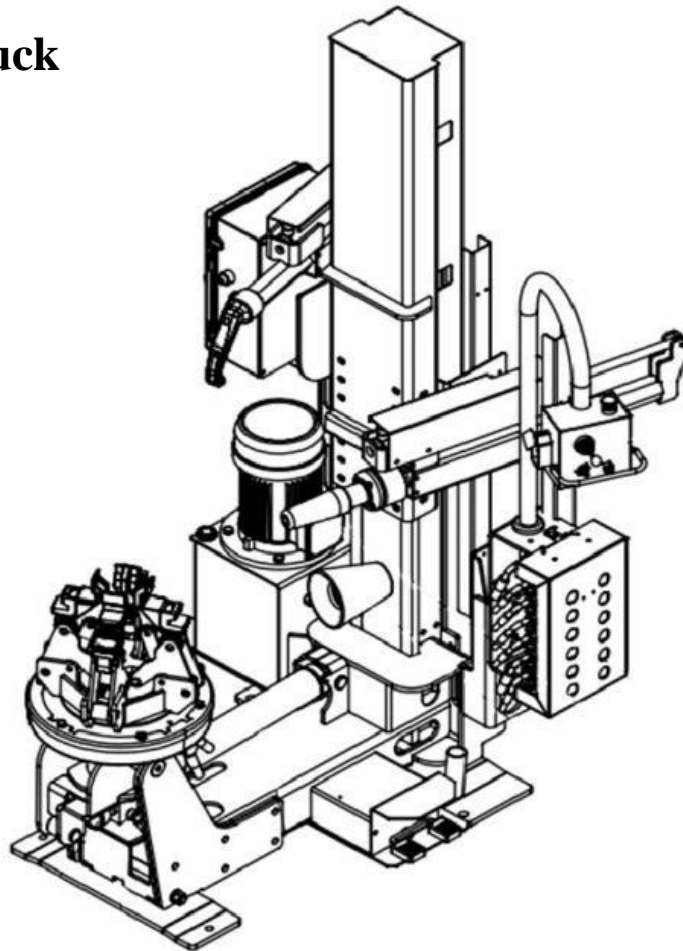

### BE SAFE

Your new Tire changer ADB-1500 was designed and built with safety in mind. However, your overall safety can be increased by proper training and thoughtful operation on the part of the operator. DO NOT operate or repair this equipment without reading this manual and the important safety instructions shown inside.

# Aston Technologies Inc.

www.astontechusa.com

ADB-1500, the Automatic Truck Tire Changer, is Invention Patented machine with continuous research, testing and development. The manner in which you care for and maintain your tire changer will have a direct effect on its overall performance and longevity.

## **READ THIS ENTIRE MANUAL BEFORE OPERATION BEGINS.**

### **PRODUCT WARRANTY**

Your new tire changer is covered under warranty for one year on equipment structure; one year on all operating components and tooling/accessories, to the original purchaser. If there is anything wrong about the components that makes the machine cannot operate, the manufacture should offer the components or parts for free.

#### **The warranty does not extend to...**

- ◆ defects caused by ordinary wear, abuse, misuse, shipping damage, improper installation, voltage or lack of required maintenance;
- ◆ damages resulting from purchaser's neglect or failure to operate products in accordance with instructions provided in the owner's manual(s) and/or other accompanying instructions supplied;
- ◆ normal wear items or service normally required to maintain the product in a safe operating condition;
- ◆ other items not listed but may be considered general wear parts;
- ◆ damage caused by rain, excessive humidity, corrosive environments or other contaminants.

**THESE WARRANTIES DO NOT EXTEND TO ANY COSMETIC DEFECT NOT INTERFERING WITH EQUIPMENT FUNCTIONALITY OR ANY INCIDENTAL, INDIRECT, OR CONSEQUENTIAL LOSS, DAMAGE, OR EXPENSE THAT MAY RESULT FROM ANY DEFECT, FAILURE, OR MALFUNCTION OF A BENDPAK INC. RANGER PRODUCT OR THE BREACH OR DELAY IN PERFORMANCE OF THE WARRANTY.**

**WARRANTY IS NOT VALID UNLESS  
WARRANTY CARD IS RETURNED.**

# TABLE OF CONTENTS

<b>Chapter1 INTRODUCTION</b> -----	1
1.1 INTRODUCTION-----	1
1.2 MACHINE IDENTIFICATION DATA-----	1
1.3 MANUAL KEEPING-----	1
<b>Chapter 2 GENERAL INFORMATION</b> -----	2
2.1 INTENDED USE-----	2
2.2 GENERAL SAFETY PRECAUTIONS-----	2
2.3 SAFETY DEVICES-----	2
2.4 PRODUCT DESCRIPTION-----	3
2.5 TECHNICAL SPECIFICATION-----	4
2.5 WARNING SIGNS_____	4
<b>Chapter 3 TRANSPORTATION, UNPACKING AND STORAGE</b> -----	5
3.1 TRANSPORTATION-----	5
3.2 UNPACKING_____	5
3.3 STORAGE_____	5
<b>Chapter 4 INSTALLATION</b> -----	5
4.1 INSTALLATION SPACE REQUIRED_____	5
4.2 WORKPLACE REQUIRED_____	5
4.3 FOUNDATION REQUIREMENT-----	6
4.4 ELECTRIC CONNECTION_____	6
<b>Chapter 5 OPERATION</b> -----	8
5.1 CONTROLS-----	8
5.2 LOCK THE WHEEL-----	8
5.3 BEAD BREAKING_____	9
5.4 DEMOUNTING_____	10
5.5 MOUNTING_____	11
5.6 WHEELS WITH LOCK RING_____	12

# TABLE OF CONTENTS

<b>Chapter 6 ORDINARY MAINTENANCE</b> .....	13
<b>Chapter 7 TROUBLE SHOOTING</b> .....	14
<b>Chapter 8 MOVING, STORING AND SCRAPPING</b> .....	14
8.1 MOVING THE MACHINE .....	14
8.2 STORING .....	14
8.3 SCRAPPING A MACHINE .....	15
<b>Chapter 9 ELECTRIC DIAGRAM</b> .....	16
<b>Chapter 10 EXPLOSIVE DRAWING</b> _____	18

## Chapter 1 INTRODUCTION

### 1.1 INTRODUCTION

Thank you for purchasing a product from the line of truck tire changers. The machine has been manufactured in accordance with the very best quality principles. Follow the simple instructions provided in this manual to ensure the correct operation and long life of the machine. Read the entire manual thoroughly and, make sure you understand it.

### 1.2 MACHINE IDENTIFICATION DATA

A complete description of our technical assistance to provide service and will facilitate delivery of any required spare parts. For clarity and convenience, we have inserted the data of your machine in the box below. If there is any discrepancy between the data provided in this manual and that shown on the name plate fixed to the tire changer, the latter should be taken as correct.

### 1.3 MANUAL KEEPING

For a proper use of this manual, the following is recommended:

- Keep the manual near the lift, in an easily accessible place.
- Keep the manual in an area protected from the damp.
- Use this manual properly without damaging it.
- Any use of the machine made by operators who are not familiar with the instructions and procedures contained herein shall be forbidden.

This manual is an integral part of the manual: it shall be given to the new owner if and when the machine is resold.



*The illustrations have been made out of prototypes pictures. It is therefore possible that some parts or components of standard*

*production differ from those represented in the pictures.*

### TO THE READER

Every effort has been made to ensure that the information contained in this manual is correct, complete and up-to-date. The manufacturer is not liable for any mistakes made when drawing up this manual and reserves the right to make any changes due the development of the product at any time.

Personal protective equipment helps make tire changing safer. However, equipment does not take the place of safe operating practices. Always wear durable work clothing during tire service activity. Shop aprons or shop coats may also be worn, however loose-fitting clothing should be avoided. Tight fitting leather gloves are recommended to protect operators' hands when handling worn tires and wheels. Sturdy leather work shoes with steel toes and oil resistant soles should be used by tire service personnel to help prevent injury in typical shop activities. Eye protection is essential during tire service activity. Safety glasses with side shields, goggles, or face shields are acceptable. Back belts provide support during lifting activities and are also helpful in providing operator protection. Consideration should also be given to the use of hearing protection if tire service activity is performed in an enclosed area, or if noise levels are high.



## Chapter 2 GENERAL INFORMATION

### 2.1 INTENDED USE

- This tire changer has been designed and manufactured exclusively for removing and mounting truck, bus and commercial van tires from/onto rims from 14" to 42" and a maximum diameter of 1500mm.
- In particular **THE MANUFACTURER** cannot be held responsible for any damage caused through the use of is tire changer for purposes other than those specified in this manual, and therefore inappropriate, incorrect and unreasonable.

### 2.2 GENERAL SAFETY PRECAUTIONS

- The machine should only be used by duly authorized and trained personnel.
- The machine should not be used for purposes other than those described in the instruction manual.
- Under no way should the machine be modified except for those modifications made explicitly by **THE MANUFACTURER**.
- Never remove the safety devices. Any work on the machine should only be carried out by specialist personnel.
- Any tampering or modification to the equipment carried out without the manufacturer's prior authorization will free the manufacture from all responsibility for damage caused directly or indirectly by the above actions.
- Removing or tampering with safety devices immediately invalidates the guarantee.
- The tire changer comes complete with instruction and warning transfers which are designed to be long-lasting. If they should for any reason be damaged or destroyed, please ask immediately for replacements from the manufacturer.

- The machine operator should avoid wearing clothes with flapping edges. Make sure at unauthorized personnel do not approach the machine during the work cycle.

### 2.3 SAFETY DEVICES

The tire changer has a number of safety devices designed to guarantee the topmost safety:

- **Check valve on the spindle opening hydraulic line** (inside the swivel connector see *Fig. B/1*). This prevents the wheel from falling from the spindle if the hydraulic line is accidentally broken.

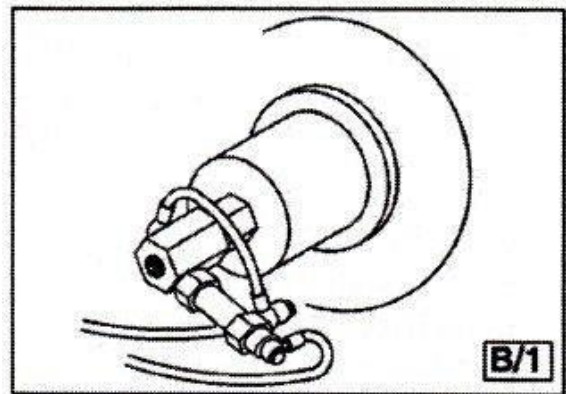

- **Pressure relief valve set at 130 bar +/-10%** (see *Fig. B/2*). This limits the pressure in the hydraulic line and ensures correct operation of the plant.

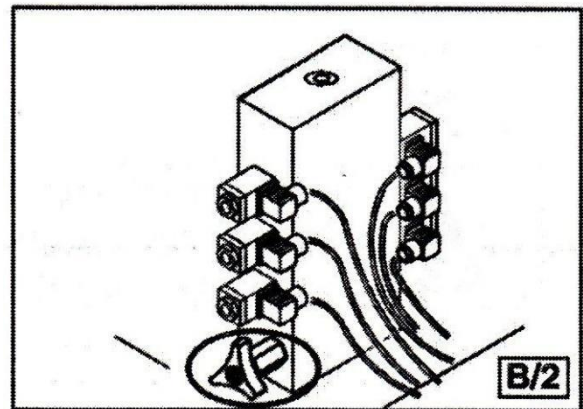

- **Pump motor overload cut-off** (inside the electric enclosure). This cuts if the motor overheats to prevent it from burning out.
- **Check valve on the chuck arm lifting hydraulic line.** It prevents the chuck arm from

descending when any accidental break occurs in the hydraulic line.

## 2.4 PRODUCT DESCRIPTION

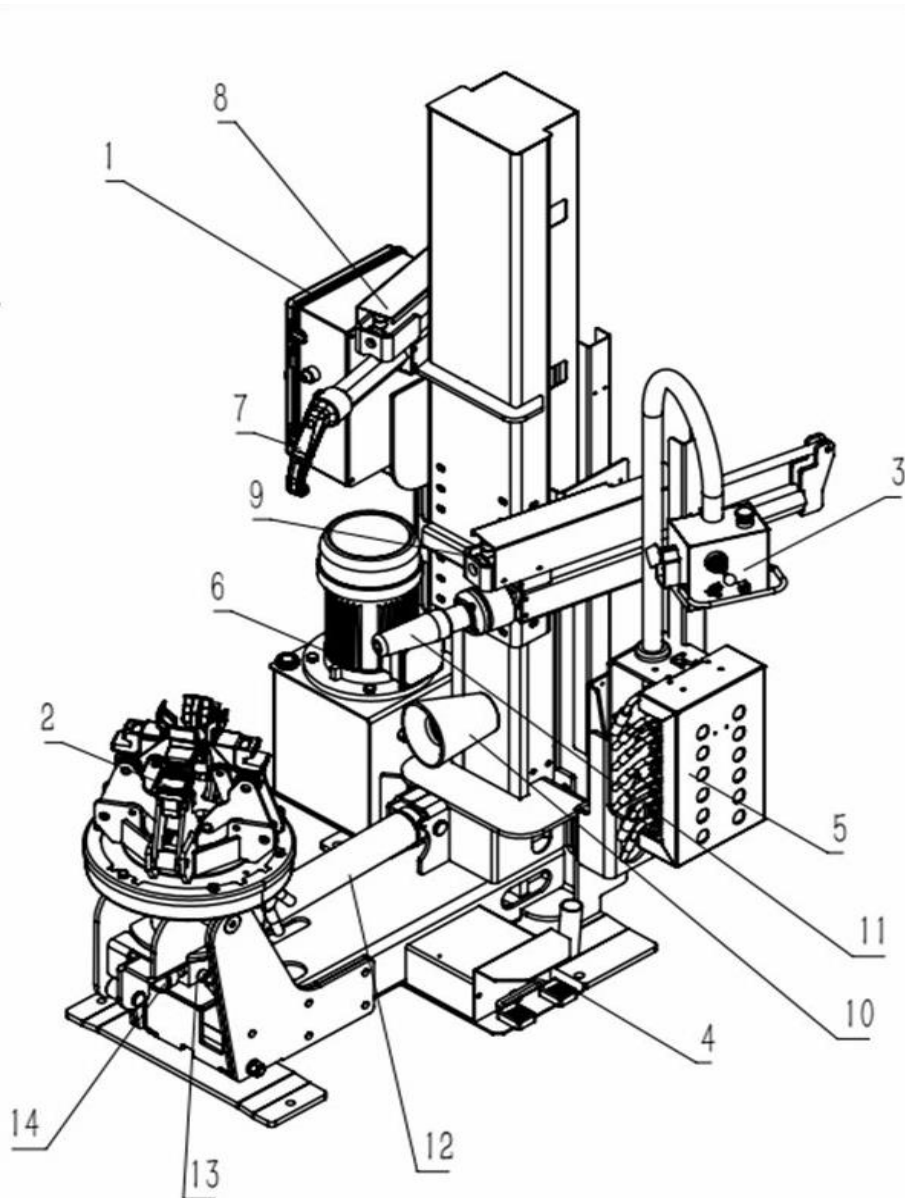

- 1. Control box
- 2. Chuck rotation unit
- 3. Hand control switch (demount tool head, pressing roller, lifting and lowering, horizontal moving)
- 4. Foot pedal switch (clockwise rotation and anticlockwise rotation)
- 5. Solenoid
- 6. Power unit
- 7. Mounting/demounting tool

8. Demount tool head cylinder
9. Pressing roller cylinder
10. Nylon pressing roller (for mounting tire or bead pressing)
11. Lock ring demount bit
12. Chuck cylinder
13. Rotation valve
14. Hydraulic pressure gauge



*During all operations, keep hands and other parts of the body as far as possible from any moving part of the machine. Necklaces bracelets and too large cloths can be dangerous for the operator.*

**2.5 TECHNICAL SPECIFICATION**

Pump motor	3.0 kw
Gear-box motor	1.5 kw
Handles rim from	14" - 42"
Max. tire diameter	1600mm
Max. tire width	780mm
Max. tire weight	1500 kg
Net weight	570kg
Noise level in working condition	< 70 dB (A)

**2.6 WARNING SIGNS**

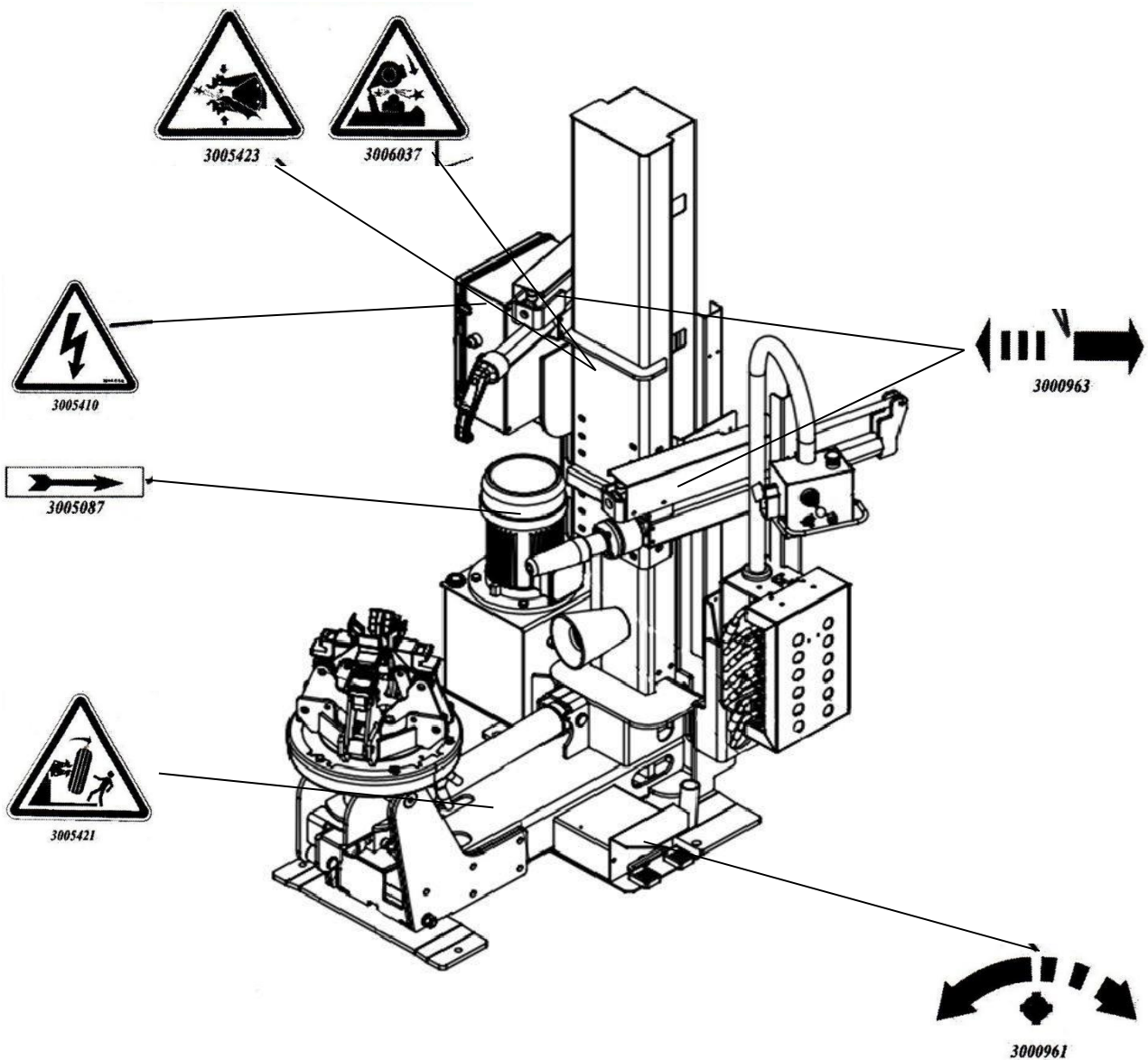

*Unreadable and missing warning labels must be replaced immediately. Do not use and add any object that could prevent the operator from seeing the labels.*

## Chapter 3 TRANSPORTATION, UNPACKING AND STORAGE

### 3.1 TRANSPORTATION

- The machine must be transported in its original packaging and kept in the position shown on the package itself.
- The packaged machine may be moved by means of a forklift truck of suitable capacity. Insert the forks at the points shown in *Fig. A/2*.

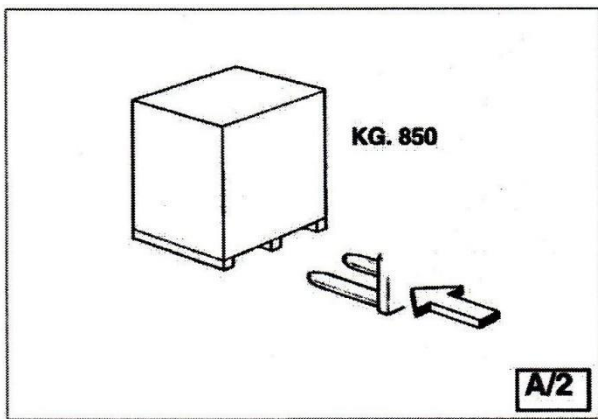

### 3.2 UNPACKING

- Remove the protective cardboard and the nylon bag.
- Check that the equipment is in perfect condition, making sure that no parts are damaged or missing.



*If in doubt, do not use the machine and contact your retailer.*

### 3.3 STORAGE

Packages must be stored in a covered place, out of direct sunlight and in low humidity, at a temperature between -10°C and +40°C.

In the event of storage for long periods of time, be sure to disconnect all sources of power and grease the clamp sliding guides on the turntable to prevent them from oxidizing.

## Chapter 4 INSTALLATION

### 4.1 INSTALLATION SPACE REQUIRED



*When choosing the place of installation, make sure that it complies with current safety at work regulations .*

- The machine must be located on a flat floor of solid construction, preferably concrete. If the floor is uneven or broken the machine will be not stable and the platform roller cannot move freely.
- If the machine is installed outside it must be protected by a lean-to.
- The following work environment conditions are applicable:
  - Relative humidity from 30-95% without condensation;
  - Temperature from 0-55°C.

### 4.2 WORKPLACE REQUIRED

- Maximum machine space requirements are 2240x1640mm with a minimum distance from walls as shown in the diagram (see *Fig. B/5*).

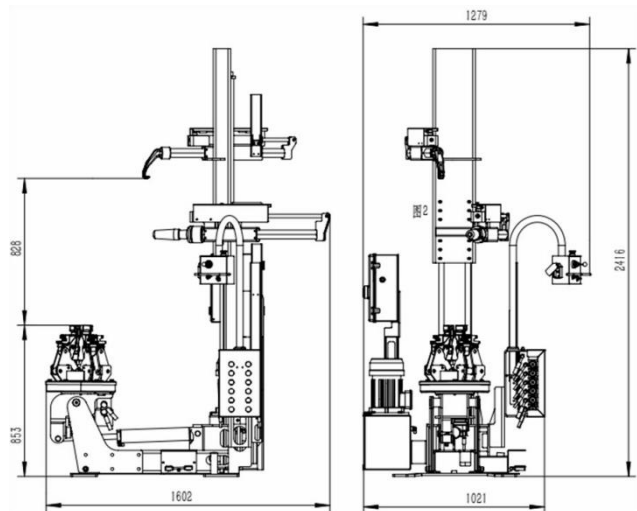

*These measurements are also the tire changer working area. Persons other than*

*pecially trained and authorized operators are extremely forbidden to enter this area.*



*When working with wheels which weight is higher than 500kg, it is necessary to fasten the tire changer to the floor by means of proper anchor bolts.*

### 4.3 FOUNDATION REQUIREMENT

The tire changer should be installed on a leveled concrete floor at least 20cm thick with a minimum concrete quality of B25 in accordance with DIN 1045 requirements (foundations).

For your reference see the drawings as well as the table below.

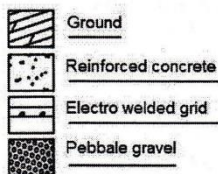
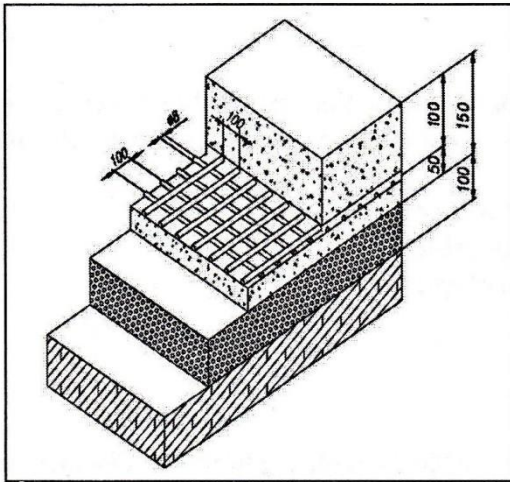

Foundations dimensions in cm.			Concrete quality	Min. pressure resistance
Length	Width	Thickness		
200	164	15	B25	425 Kg / cm <sup>2</sup>

If a floor of this type is not available on site, fastening points of the specified concrete quality are acceptable.

- Surface, on which the tire changer is to be installed, must be flat and well leveled in all directions.
- Inclination up to 0.25% relative to the horizontal can be compensated using suitable shims wedges or the alike.

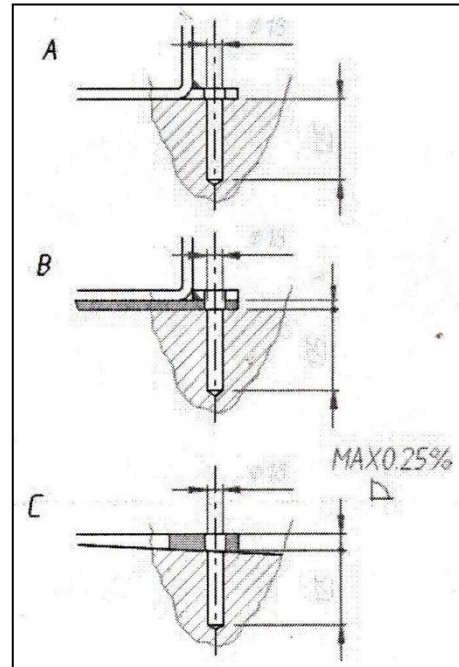

- By means of a hammer drill D.16, drill at least 130mm into the floor passing through the holes provided on the base frame.
- If there is an additional floor covering (B), or if shims or wedges are necessary for leveling (C), longer bolts must be used.
- Place an anchor bolt into each hole.
- Make sure the anchor bolts extend at least 125mm into the concrete slab, as indicated in the drawings.

### 4.4 ELECTRIC CONNECTION



*Any electric connection job must be carried out by professionally qualified personnel.*

- Check to make sure the characteristics of your systems correspond to those required by the machine. The supply voltage (and main

frequency) is given on the machine nameplate. It cannot be changed.

- Connect the machine to the main electric power supply.  
If the machine does not include the electric plug, the user must set one, which must conform to the voltage of the machine, in compliance with the regulations in force.
- The machine should not be started up without proper grounding.



*It is absolutely essential that:*

*The machine is connected to a power supply line circuit breaker set for 30mA. The current intake is adequately protected against over currents with fuses or automatic magneto-thermic switch with rated value as shown in the table.*

Power supply	Rated current	
	Fuse	Switch
220V/230V - 3ph - 50/60Hz	25A AM	25A
380V/440V - 3ph - 50/60Hz	16A AM	16A

- Open the control panel;
- Switch the breaker on (*Fig. B/3*)

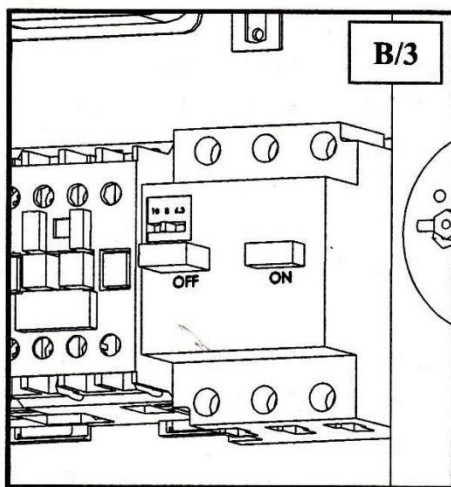

- Switch "ON" (5, *Fig. B/7*) and check that the gearbox motor rotation corresponds to the indicating arrow (6, *Fig. B/6*).

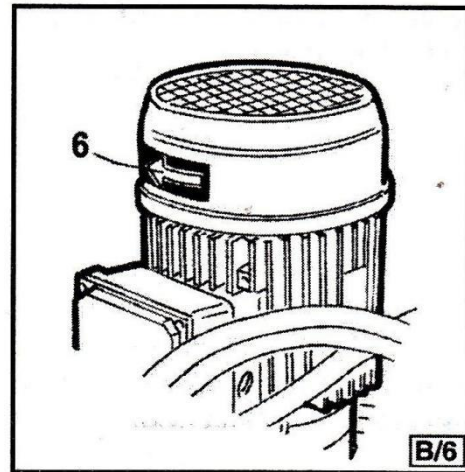

- If not, switch two wires in the plug.

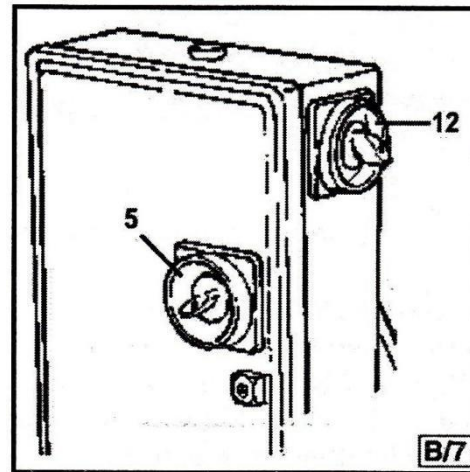

## Chapter 5 OPERATION

### 5.1 CONTROLS

The control center (*Fig. C*) enables the operator to work at any position around the machine. On this control center the following controls are located:

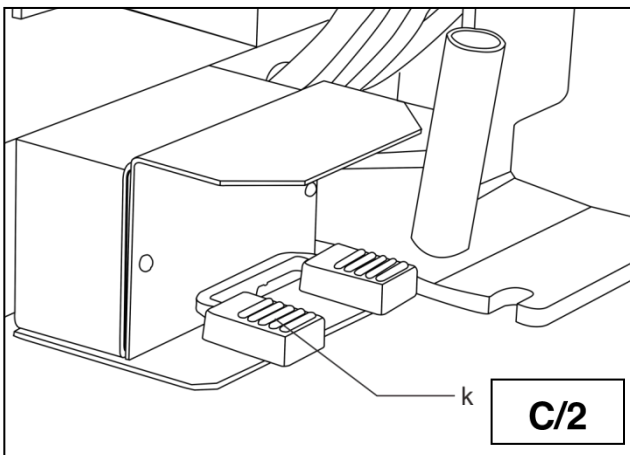
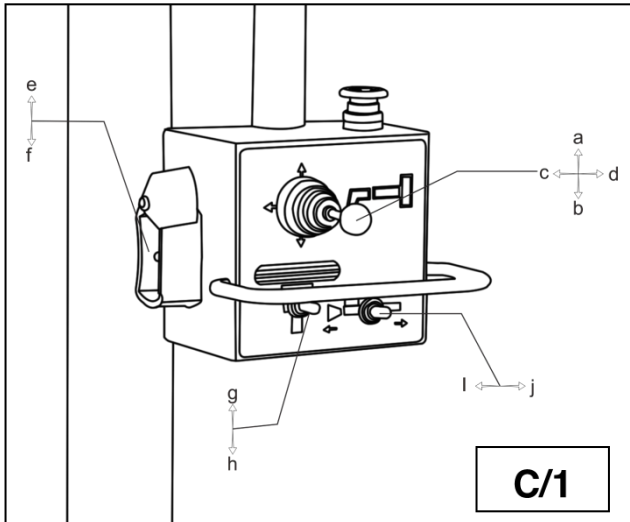

- **The lever (Fig. C/1)** which in position [a] lifts the chuck arm and in position [b] lowers it; in position [c] moves the tool holder arm and the sliding table towards the self-centering chuck and in position [d] moves them back.
- **The chuck switch (e/f, Fig. C/1)** when moved upwards [e], opens the arms of the self-centering chuck (LOCKING), and when moved down [f], closes the arm of the self-centering chuck (Opening).
- **The bead pressing roller switch (i/j, Fig. C/1)** which in position [i] moves the arms of the bead

pressing roller towards the self-centering chuck and in position [j] moves them back.

- **The bead pressing roller switch (i/j, Fig. C/1)** which in position [i] moves the arms of the bead pressing roller towards the self-centering chuck and in position [j] moves them back.
- **The tire lifting switch (g/h, Fig. C/1)** which in position [g] lifts the tire and in position [h] lowers it.
- **The pedal (Fig. C/2)** when pressed on the left or right side rotates the self-centering chuck in the same direction as shown by the arrows placed on the foot pedal.

### 5.2 LOCKING THE WHEEL



*In locking the wheel, make sure that clamps are properly positioned on the rim, so as to prevent the tire from falling.*



*This operation can be extremely dangerous. Do it manually only if you are certain you can keep the wheel balanced.*

*For large and heavy tires an adequate lifting device must be used.*

- 4) Operate joystick to lift or lower the chuck in order to center the self-centering chuck relative to the rim.
- 5) With the jaws in the closed position, move the wheel to the self-centering chuck. Operate the chuck switch (e/f, Fig. C/1) to open the self-centering chuck and lock onto the inside wheel rim.

The most convenient locking position on the rim may be selected according to *Figs E/1-E/2-E/3-E/4-E/5 and E/6.*

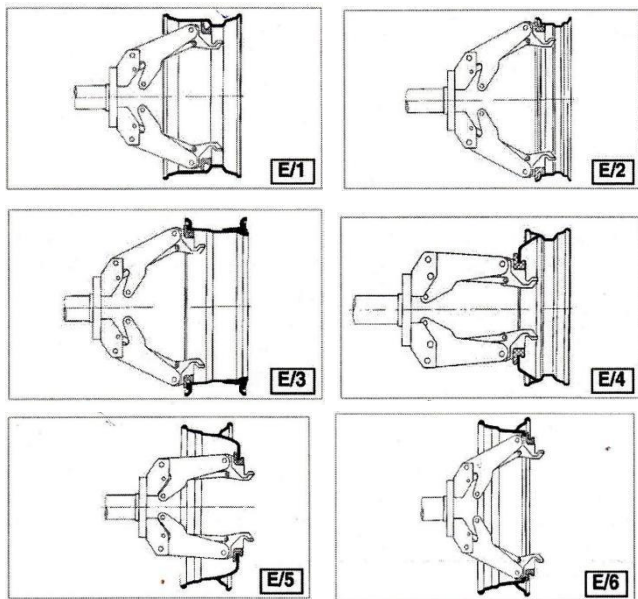

*Always remember that the safest locking is on the central FLANGE.*

*For rims with channel, clamp the wheel so that the channel is near the outside of the rim (Fig. E/1).*

### 5.2.1 LIGHT-ALLOY RIM LOCKING

Art.137/90 clamps: especially designed for operating on light alloy rims without damaging them and is available upon request.

The clamps are to be inserted (bayonet-like mounting) into the clamp support of the self-centering chuck (see Fig. E/7).

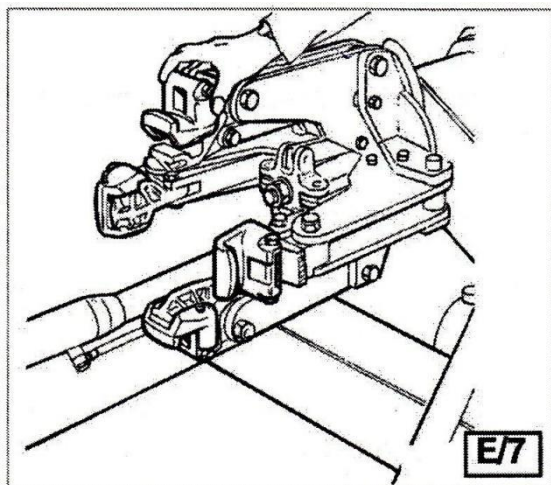

Lock the rim as illustrated in **Fig. E/8**. The specially made pliers Art.138/90 should be attached to the outside edge of the alloy rim at the highest point.

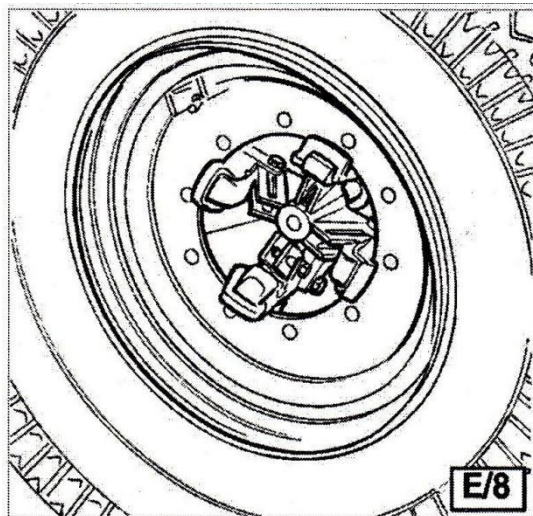

*Do not leave the work area with a wheel clamped on the tire changer and lifted up from the floor.*

### 5.3 BEAD BREAKING

1) Lock the wheel on the self-centering chuck, as previously described, and ensure that the tire is deflated.



*Always check to be certain that the arm is corrected hooked to the carriage.*

2) Operate the bead pressing roller switch (i, Fig. C/1) until the outside of the rim skims the bead pressing roller.



*The bead pressing roller must NOT be pressed against the rim but against the tire bead.*

3) Rotate the wheel and at the same time advance the bead pressing roller with small movements downward according to the profile of the rim.



4) Continue until the first bead is fully detached. To facilitate this operation, lubricate the bead and the edge of the rim with tire lubricant whilst the wheel is rotated.

**Remember: stronger the tire's adherence to the rim, the slower must be the roller's penetration.**



**To avoid all risks, lubricate the beads turning the wheel clockwise if you are working on the outside plane and anticlockwise if working on the inside plane.**

5) Bring the bead pressing arm back from the edge of the rim. And lower the arm to the downside of the tire.



**Do not hold your hands on the tool when you bring it back to its work position. Your hand(s) could be frapped between the tool and the wheel.**

6) Repeat the operation previously described until the second bead is completely broken.

## 5.4 DEMOUNTING

- Apply tire manufacturer's approved rubber lubricant liberally to entire circumference of both tire beads after loosening.

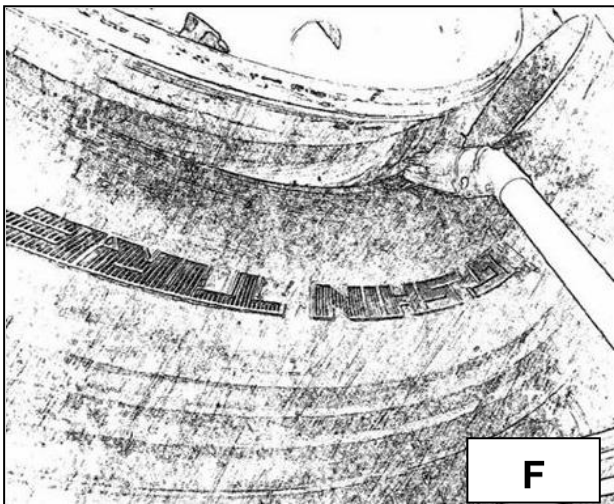

- Rotate the wheel and at the same time move the hook tool forward to insert it between rim

and bead until it is anchored to the bead (See Fig. G).

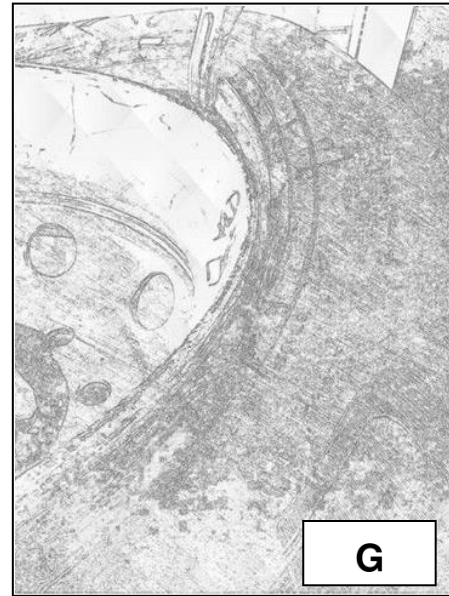

- Move the hook tool 4-5 cm from the rim taking care that it does not unhook from the bead.
- Move the hook tool upwards until the reference dot is by the outside edge of the rim.
- Turn the wheel anticlockwise pressing down on pedal until the bead is completely off.
- Move the bead pressing roller carrier arm to downside plane of the wheel.



- Move the roller upwards so that its reference dot is about 3 cm outside the rim.

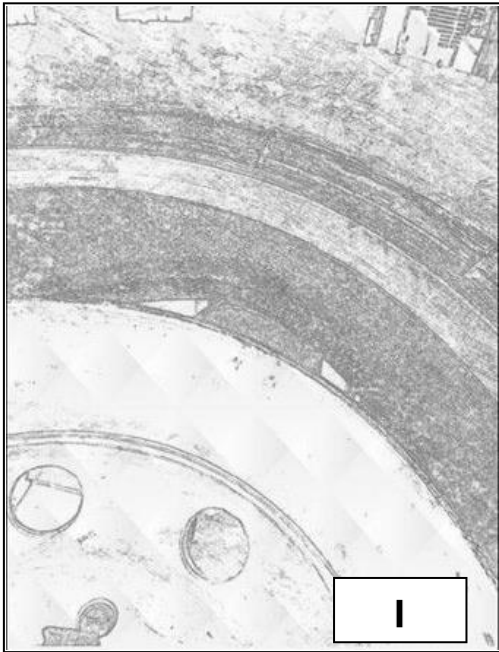

- Turn the wheel clockwise pressing down on pedal until the tire comes completely off the rim.



*When the beads come off the rim the tire will fall. Check to make sure there are no by-standers in the work area.*

### 5.5 MOUNTING

Tubeless tires can be mounted using either the **bead pressing roller** or the **hook tool**.

If the tire is not problematic, use the bead pressing roller.

If the tire is very rigid, the hook tool must be used.

- 1) If the rim has been removed from the chuck, put it back on the chuck as described in the section on "CLAMPING THE WHEEL".
- 2) Lubricate both beads and the rim with tire manufacturer recommended lubricant.
- 3) Attach the clip to the outside edge of the rim at the highest point (See Fig. M). **Make sure the clip is firmly attached to the rim.**

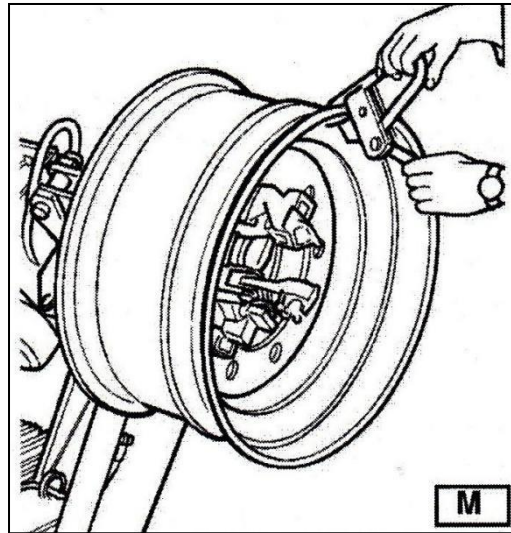

- 4) Lean the tire against the rim.
- 5) Lift the rim with the hook to it and turn it clockwise about 15-20 cm. The tire will be positioned tilted across the rim.

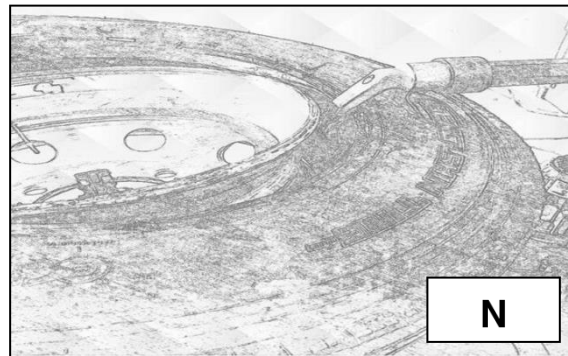

- 6) Position the hook against the second bead of the tire.
- 7) Move the hook forward until it is about 1-2 cm inside the edge of the rim. Begin to turn the spindle clockwise checking to make sure that, with a 90° turn, the second bead begins to slip into the center well.
- 8) When the second bead is fully mounted, move the hook downside for about 4cm. Turn the spindle clockwise until the first bead is fully mounted. And remove the clip.
- 9) Lower the spindle until the wheel rests on the floor.
- 10) Close the chuck of the spindle completely. Support the wheel to prevent it falling off.



*This operation can be extremely dangerous.*

*Do it manually only if you are certain you can keep the wheel balanced.*

*For large and heavy tires, an adequate lifting device must be used.*

## 5.6 WHEELS WITH LOCK RING

### 5.6.1 DEMOUNTING

- 1) Clamp the wheel on the spindle as described previously and check to make sure it has been deflated.
- 2) Replace the bead pressing roller with lock ring demount bit.
- 3) Position the lock ring demount bit with the rim (*See Fig. W*).

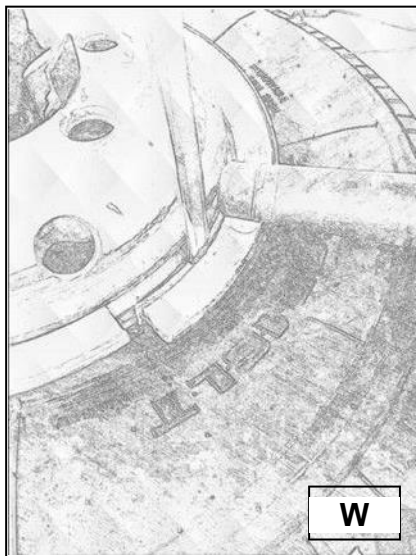

- 4) Press down the demount bit until the lever can be inserted between the lock ring and the rim. Separate the lock ring from the rim.
- 5) Move and insert the demount bit to the bottom of the lock ring.
- 6) Move the demount bit upwards to lift the lock ring to the outside of the rim.



- 6) Turn the spindle clockwise until the lock rim is fully separated.
- 7) Follow 5.5.2 to demount the tire.

### 5.6.2 MOUNTING

- 1) Follow 5.5.3 to mount the tire.
- 2) Replace the demount bit to bead pressing roller.
- 3) Put the lock rim on the tire. Position the demount bit to one end of the lock rim.
- 4) Press the lock rim to the inside of the rim.
- 5) Insert the lever to keep the lock rim in position.
- 6) Turn the spindle clockwise until the lock rim is completely seated.
- 7) Lower the spindle until the wheel rests on the floor.
- 8) Close the chuck of the spindle completely. Support the wheel to prevent it falling off.



*Do not inflate the tire with the wheel mounted on the spindle.*

*Tire inflation is dangerous and should only be done by removing the wheel from the spindle and placing it inside a safety cage.*

## Chapter 6 ORDINARY MAINTENANCE



*Each maintenance operation must be affected only after the disconnection of the plug from electric network.*

To ensure that this tire changer works perfectly over the years, carry out the routine maintenance schedule described below:

1) Lubricate the following parts from time to time after a thorough cleaning with naphtha:

- the various swivels on the spindle
- the tool bracket slide runner
- the carriage guide plate.

2) Grease the spindle bracket lift cylinder from time to time and also its swivel. Add the grease through the grease nipples (*See Fig. J*) using ordinary lubricating grease.

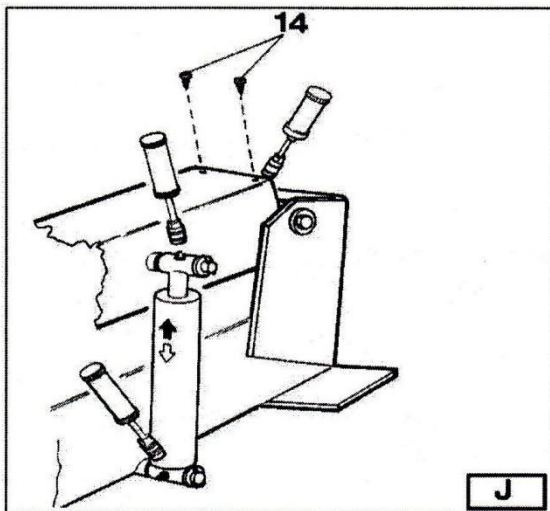

3) From time to time check the oil level in the hydraulic power pack. Use the dipstick under the reservoir cap.

If necessary top up with Esso Nuto H46 or similar hydraulic oil (eg, Agip Oso 46, Shell Tellus Oil46, Mobil DTE 25, Castrol Hyspin AWS 46, Chevron RPM EP Hydraulic Oil46, BP Energol HLP).

4) From time to time check the oil level in the gear unit which, when the tool carrier bracket is completely lowered at end travel, should not show the sight glass on the gear casing as completely empty. If necessary top up with Esso Spartan EP 320 or similar oil (eg, Agip FI REP 237, BP GRX P 320, Chevron Gear Compound 320, Mobil Gear 632, Shell Omala Oil 320, Castrol Alpha SP 320).



*If the oil in the gear unit or the hydraulic power pack has to be changed, note that the gear unit and the power pack reservoir have specific drain plug.*



*Dispose of the used oil following the present legislation on the matter.*

## Chapter 7 TROUBLE SHOOTING

TROUBLE:	POSSIBLE CAUSE:	SOLUTION:
After having switched on the power switch, the pilot lamp does not light on and no control can function.	The power plug is not inserted.	Insert the plug correctly in its socket.
	No power from the mains electric supply.	Reset the mains electric supply.
After having switched on the power switch, the pilot lamp light on but the motor on the hydraulic power pack does not function.	The circuit breaker is not switched on.	Switch on the circuit breaker.
	The magneto-thermic switch for motor protection is working.	Call for technical assistance.



*If, despite of the above-mentioned indications the tire changer does not work properly do not use it and call for technical assistance.*

## Chapter 8 MOVING, STORING AND SCRAPPING

### 8.1 MOVING THE MACHINE

The tire changer has got the lifting bracket (**1, Fig. A**) which has been positioned there on purpose for moving the machine.

To move the machines, follow these instructions:

- 1) Low the chuck holding arm (**2, Fig. A**) completely down.
- 2) Close completely the jaws of the chuck (**3, Fig. A**).
- 3) Bring the sliding table (**4, Fig. A**) at the end of its travel, near the arm.
- 4) Insert into the lifting bracket a hoisting belt (at least 60 mm wide and of a length sufficient to bring the hook of the belt above the tire changer).

5) With the special belt ring bring the 2 ends of the belt together and lift the machine with a sufficiently strong lifting truck.

### 8.2 STORING

If the machine as to be stored for a long time (3-4 months) you have to:

- 1) Close the jaws of the chuck; low the chuck holding arm down; low the tool holding arm down in working position.
- 2) Disconnect the machine from all power sources.
- 3) Grease all the parts that could be damaged if they dry out:
  - the chuck
  - the slot of the tool holding arm
  - the slides of the carriage
  - the tool

4) Empty oil/hydraulic fluid reservoirs and wrap the machine in a sheet of protective plastic to prevent dust from reaching the internal working parts.

If the machine as to working again after a long storing period, it is necessary to:

- fill the oil into the reservoirs again.

### 8.3 SCRAPPING A MACHINE

When your machine's working life is over and it can no longer be used, it must be made inoperative by removing any connection to power sources.

These units are considered as special waste material and should be broken down into uniform parts and disposed of in compliance with current laws and regulations. If the packing is not polluting or non-biodegradable, deliver them to appropriate handling station.



*If this machine catches fire, use dust or CO<sup>2</sup>.*

### Chapter 9 ELECTRIC DIAGRAM

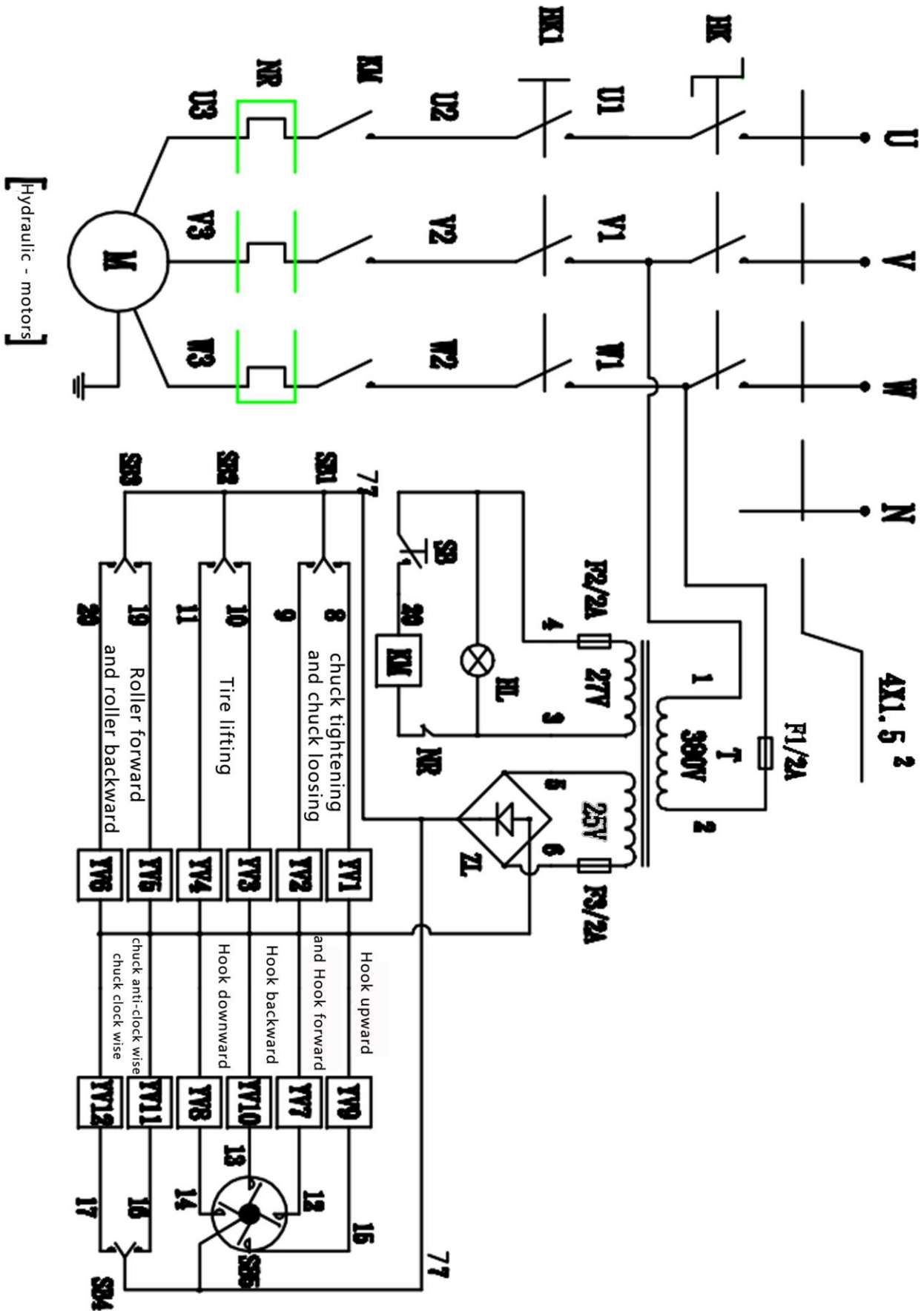

S/N	Code	Description	Specification	Qty.	Mark
1	HK	Power switch	EN60947-1/20A	1	
2	HK1	Circuit breaker	DZ47-60/D20	1	
3	KH	Contacto	CJX2-1801/AC24V	1	
4	T	Transformer	BK380V/100VA/27V/25V	1	Applicable to single phase power: BK220V/27V/25V
5	F1-F3	Fuse	2A	3	
6	ZL	Rectifier	KBPC3510	1	
7	HL	Power indicator	AD16-AC24V	1	Green
8	SB	Emergency button	ZB2-BE102C	1	
9	SB1-SB3	Button switch	E-TEN123	3	
10	SB4	Pedal switch	EKW-5A-B	2	
11	SB5	Cross switch	RNIL~CS four-way	1	
12	YV1	DC/Solenoid	4WE6-G-60/G24-Z5L	1	Chuck tightening
13	YV2	DC/ Solenoid	4WE6-G-60/G24-Z5L	1	Chuck loosing
14	YV3	DC/ Solenoid	41E6-G-60/G24-Z5L	1	Tire Lifting
15	YV4	DC/ Solenoid	4IE6-G-60/G24-Z5L	1	Tire Lifting
16	YV5	DC/ Solenoid	4IE6-G-60/G24-Z5L	1	Roller forward
17	YV6	DC/ Solenoid	41E6-G-60/G24-Z5L	1	Roller backward
18	YV7	DC/ Solenoid	4WE6-G-60/G24-Z5L	1	Hook upward
19	YV8	DC/ Solenoid	4WE6-G-60/G24-Z5L	1	Hook downward
20	YV9	DC/ Solenoid	4WE6-G-60/G24-Z5L	1	Hook forward
21	YV10	DC/ Solenoid	4WE6-G-60/G24-Z5L	1	Hook backward
22	YV11	DC/ Solenoid	4WE6-G-60/G24-Z5L	1	Chuck anti-clockwise
23	YV12	DC/ Solenoid	4WE6-G-60/G24-Z5L	1	Chuck clockwise
24	M	Hydraulic pump motor	380V/1.5KW	1	
25		Connection terminal	H3801-12	1	

## Chapter 10 EXPLOSIVE DRAWING

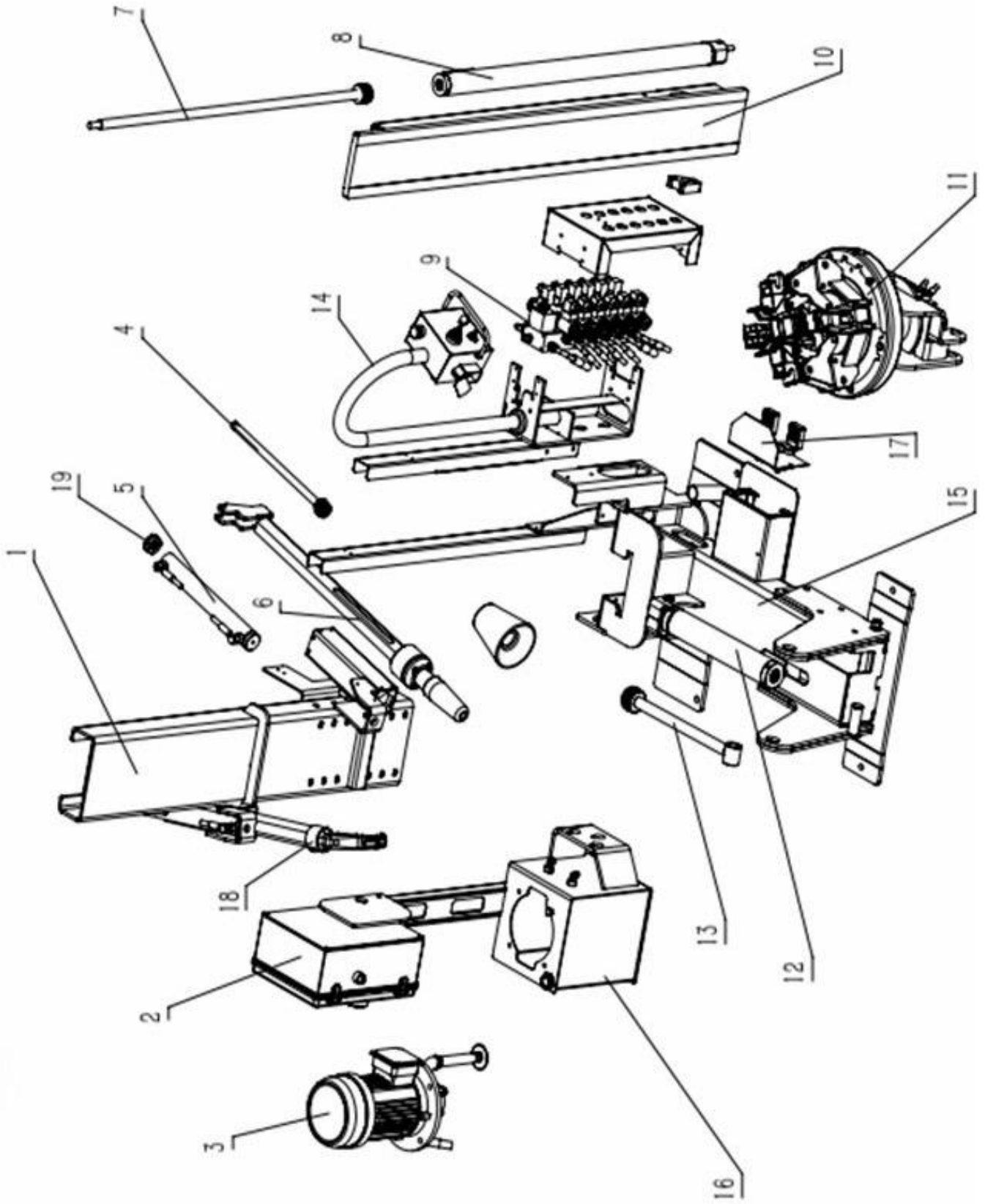

S/N	Parts Nr.	Description	Qty.	Mark
1	1508300	Slider welding assembly	1	
2	1501115	Control box	1	
3	1503100	Gear box assembly	1	
4	1506100	Horizontal arm cylinder assembly	2	
5	1506200	Horizontal arm cylinder welding assembly	2	
6	1505000	Demount bit assembly	1	
7	1507000	Piston assembly	1	
8	1506000	Slider cylinder assembly	1	
9	1508000	Solenoid valve assembly	1	
10	1502000	Vertical column welding assembly	1	
11	1504600	Chuck assembly	1	
12	1612800	Moving arm cylinder assembly	1	
13	1502900	Piston assembly	1	
14	1509400	Control unit assembly	1	
15	1501000	Body assembly	1	
16	1509000	Oil tank assembly	1	
17	1501200	Pedal assembly	1	
18	1503001	Hook	1	
19	1506300	Cylinder cap assembly	2	

## LIMITED WARRANTY

Aston® Wheel Service Equipment is warranted for the period of one year on all operating components to be free of defects in material and workmanship. Aston® shall repair or replace at their option for the warranty period those parts returned to the factory freight prepaid which prove upon inspection to be defective. Aston® will pay labor costs for the first 12 months only on parts returned as previously described. These warranties do not extend to defects caused by ordinary wear, abuse, misuse, shipping damage, improper installation, or lack of required maintenance. This warranty is exclusive and in lieu of all other warranties expressed or implied. In no event shall Aston® be liable for special, consequential, or incidental damages for the breach or delay in performance of the warranty. Aston® reserves the right to make design changes or add improvements to its product line without incurring any obligation to make such changes on product sold previously. Warranty adjustments within the above stated policies are based on the model and serial number of the equipment. This data must be furnished with all warranty claims.